



▶▶▶ *Earthing & Grounding*



Manufacturer Head Office:

 **LYTECH**

Email: sales@lytech.uk | marketing@lytech.uk
Website: www.lytech.uk

Ver : LYT-1-4

▶▶▶ About LYTECH Technologies

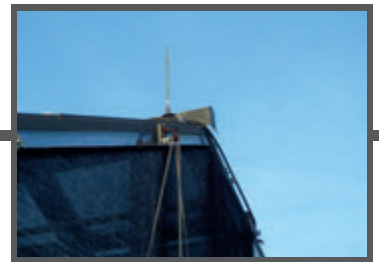

About

LYTECH Technologies provides a total solution from lightning protection and earthing systems to lightning and surge protection for electrical and electronic equipments.

Our lightning and earthing systems are manufactured strictly to the international standards such as **IEC 62561 and IEC 62305, UL Standards and Singapore Code of Practice SS555 for lightning protection.**

We control the quality of our products from raw materials to finished products to ensure top quality products are produced.

LYTECH Technologies provides a total solution for lightning protection from designing stage to supplying and installing a complete system. Our dedicated technical support team and sales team guarantee top quality service and select the most appropriate products to our customer's stringent demands.

LYTECH Technologies has participated in various mega projects in Singapore and around the South East Asia region.

▶▶▶ About LYTECH Technologies

LYTECH Technologies is a total solution provider for earthing, lightning and surge protection system in Asean.

Our Earthing and Lightning Protection System products (LYTECH) are manufactured to comply to **IEC 62561**, where the components have undergone **Salt Mist Test 60068-2-52:1996, severity 2 (72 hours exposure)**. Our dedication allows us to produce and customised products that cater to the demands of our customers.

Our lightning protection system design and lightning risk assessment reports complies to **IEC62305 / SS555 standards**. Our design team is also capable to propose design based on **American (UL, API) and French (NFC) standards**. With our capabilities and technical know how, we can offer sophisticated and customer orientated technical support, meeting our customers stringent requirements.

We based our earthing design on **IEEE80** and we use CDEGS software to produce efficient and safe earthing system via the simulation of fault current discharge on step and touch voltages.

With our expertise, quality service, adequate stocking and short decision making process, we are well placed to cater to your needs to earthing, lightning and surge protection system requirements.

■ Total Solution to Earthing and Lightning Protection System

LYTECH Technologies offers a total solution to all your earthing and lightning protection issues. With our technical know-how on the latest standards (**IEC, UL, API, NFC IEEE80**), besides offering the most optimum design, we can produce customised products to suit your project requirements.

Lightning is one of nature's most destructive phenomena, and can cause massive damage and destruction if a structure is not adequately designed and equipped with proper earthing, lightning and surge protection system. Sever cases even involved injuries and even death to personals.

The secondary effect of lightning, called surge or transient overvoltages, can easily damage electronics housed within the structure.

A reliable lightning protection system design, as per **IEC62305 / SS555**, encompasses both structural lighting (**part 3 - physical damage to structures and life hazard**) and surge protection system (**part 4 - electrical and electronic systems within structures**), complete with lightning risk assessment report (**part 2 - risk management**).

Apart from applying international standards to the lightning protection system, the lightning protection system components has to be correctly installed, using quality products and fixings to ensure the effective dissipation of lightning energy safely to the ground. Apart from the professional implementation, the lightning protection system has to be inspected at various intervals to ensure its effectiveness.

LPS Level	Visual Inspection	Complete Inspection	Critical Facilities
I & II	1 year	2 years	1 year
III & IV	2 years	4 years	1 year

■ External Lightning Protection

The external lightning protection system is designed to protect a structure and the lives of people working within it, by directing the lightning energy in a safe manner to the earthing network. Using the Faraday Cage principle, the **LYTECH** range of quality lightning protection and earthing products ensures that safety and performance is not compromised.

Our products are tested under the following standards:

- **IEC 62561-1-2012**
Lightning protection system components (LPSC) – Part 1: Requirements for connection components
- **IEC 62561-2-2012**
Lightning protection system components (LPSC) – Part 2: Requirements for conductors and earth electrodes
- **IEC 62561-4-2010**
Lightning protection system components (LPSC) – Part 4: Requirements for conductor fasteners
- **Salt Mist Test 60068-2-52:1996, severity 2 (72 hours exposure)**

■ Earthing System

To ensure that our client always gets the most optimum design to meet the international standards, and their budget, we offer the following services :

- Lightning and surge protection system design and audit based on **IEC62305 / SS555, UL, API, and NFC standards**, complete with detailed drawings
- Soil resistivity and earth resistance test
- Training based on **IEC62305 / SS555**, and practical training on exothermic welding

■ Lightning Protection System Design

The earthing network ensures that lightning energy can be dissipated in a safe and efficient manner. Our range of LYTECH Exothermic Welding components provides a fast and easy way of creating good quality exothermic welding joints that can tolerate the fault current of all facilities.

■ Earthing System Design

Our design for earthing system is on **IEEE80** and we use the CDEGS software for Finite Element Analysis (FEA) of fault current discharge for step and touch voltages. To design an earthing system, our engineers can conduct a site survey and soil resistivity test and together with the fault current details, we can construct a total design complete with detail report which will also include step and touch voltages values clearly indicated within the earth mat.

▶▶▶ About LYTECH Technologies

■ LYTECH Technologies Advantage

We offer a one stop shop concept by providing total solution to earthing and lightning system design, and we keep stock for all common items.

Our design complies to all relevant international standards.

Our experience in this field allows us to provide our clients with optimum design that meet the international standard, as well as best use of resources

With our manufacturing expertise and experience, we can offer our clients customised solutions and products to meet their needs.





Certificate of Registration

QUALITY MANAGEMENT SYSTEM - ISO 9001:2015

This is to certify that:

Lytech Technologies Pte Ltd
51 Ubi Avenue 1
#05-22 Paya Ubi Industrial Building
Singapore 408933

Holds Certificate No:

FM 665172

and operates a Quality Management System which complies with the requirements of ISO 9001:2015 for the following scope:

The design, manufacture & sales of lightning and earthing materials

For and on behalf of BSI:

Michael Lam - Managing Director Assurance, APAC

Original Registration Date: 2017-01-14

Latest Revision Date: 2022-12-15

Effective Date: 2023-01-14

Expiry Date: 2026-01-13

Page: 1 of 1



...making excellence a habit.™

This certificate was issued electronically and remains the property of BSI and is bound by the conditions of contract.

An electronic certificate can be authenticated [online](#).

Printed copies can be validated at www.bsi-global.com/ClientDirectory or telephone + (65)62700777.

Further clarifications regarding the scope of this certificate and the applicability of ISO 9001:2015 requirements may be obtained by consulting the organization. This certificate is valid only if provided original copies are in complete set.

Information and Contact: BSI, Kitemark Court, Davy Avenue, Knowlhill, Milton Keynes MK5 8PP. Tel: + 44 345 080 9000
BSI Assurance UK Limited, registered in England under number 7805321 at 389 Chiswick High Road, London W4 4AL, UK.
A Member of the BSI Group of Companies.

Earth Rod



IEC 62561-2:2018

Copperbonded Earth Rod

Earth rods are usually made from either solid copper, stainless steel or copperbonded steel.

Copperbonded earth rod is the most popular due to its combination of strength, corrosion resistance and cost effectiveness. It also meets all the requirements under international standards (IEC62305, IEC62561 and UL467).

Our earth rods are manufactured by molecularly bonding of pure electrolytic copper onto low carbon high tensile steel cores, making it highly resistant to corrosion. Moreover, the copper surface will not be separated from the steel core when hammering into the ground.

Our manufacturing process ensures uniform plating thickness reliable and free from imperfections or peeling. The copper thickness is 250 microns.

Length is more important than diameter

Apart from considerations of mechanical strength, there is little advantage to be gained from increasing the earth rod diameter with the object in mind of increasing surface area in contact with the soil.

The depth to which an earth rod is driven has much more influence on its electrical resistance characteristics than has its diameter. This is because it is not the actual area of contact with the soil that counts, so much as the total resistance area of the sheath or shell surrounding the earth rod.

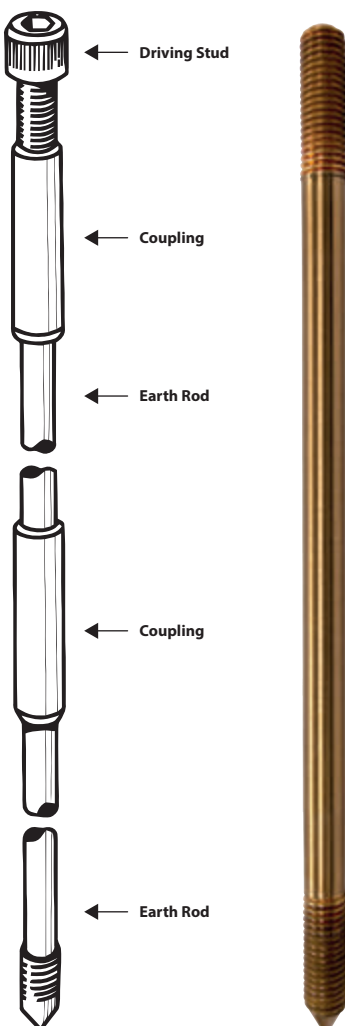

Part No.	Rod Diameter (mm)	Thread Diameter (inch)	Length (mm)
CER5812	14.2	5/8	1200
CER5815	14.2	5/8	1500
CER5818	14.2	5/8	1800
CER5824	14.2	5/8	2400
CER5830	14.2	5/8	3000
CER3412	17.2	3/4	1200
CER3415	17.2	3/4	1500
CER3418	17.2	3/4	1800
CER3424	17.2	3/4	2400
CER3430	17.2	3/4	3000

**Other diameters and lengths are available upon request*

**We can also supply unthreaded rods upon request*

Earth Rod



Galvanised Steel Earth Rod

The galvanised steel earth rods are made from high tensile steel and galvanised for corrosion protection.

Part No.	Rod Diameter (mm)	Length (mm)	Internal Threading
GSR16MM-3M	16	3000	M10
GSR20MM-3M	20	3000	M10

Earth Rod

Solid Copper and Stainless Steel Earth Rod

The solid copper earth rods are made from 99.9% pure copper which offers great resistance to corrosion. It can be applied in an area where soil is high corrosive. The stainless steel earth rods are made from high grade SS316 quality which can be used in ground where corrosion level can be high.

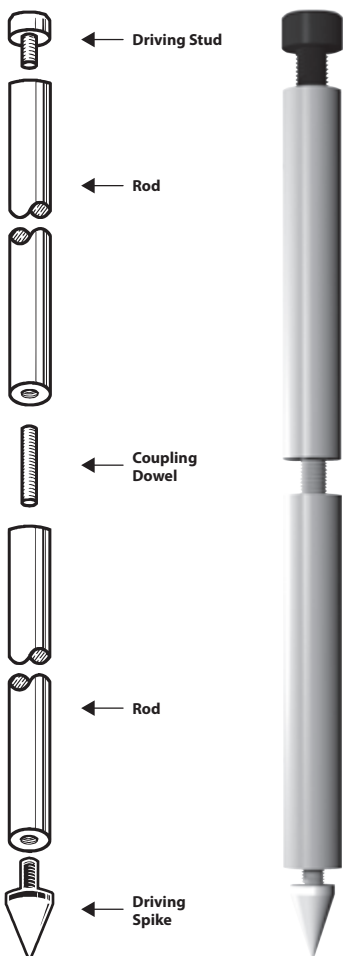

Solid Copper Earth Rod

Part No.	Rod Diameter (mm)	Length (mm)	Internal Threading
SCER15-C	15	1200	M10
SCER20-C	20	1200	M10

**Other diameters and lengths are available upon request*

**We can also supply unthreaded rods upon request*

Stainless Steel Earth Rod

Part No.	Rod Diameter (mm)	Length (mm)	Internal Threading
ER1612-SS	16	1200	M10

**Other diameters and lengths are available upon request*

**We can also supply external threaded SS316 earth rods upon request*

**Other grade of stainless steel is also available*

Fittings

Part No.	Thread Diameter	Type
SCCD-10	M10	Coupling Dowel
SCDS-10	M10	Driving Stud
SCDP-10	M10	Driving Spike

Earth Rod



IEC 62561-2:2018

*



**



Earth Rod Coupling

Our earth rod couplings are made from high tensile strength copper. This ensures high tensile strength and excellent corrosion resistance.

Part No.	Thread Diameter (inch)	Conductor Type
*ERC58	5/8	Copper
*ERC34	3/4	Copper
**ERC58-HD	5/8	Copper
**ERC34-HD	3/4	Copper

Earth Rod



Driving Stud

The driving studs are made of re-usable high tensile strength steel which can be use multiple times. It is also suitable for power hammering.

Part No.	Thread Diameter (inch)	Material
EDS58	5/8	High Tensile Steel
EDS34	3/4	High Tensile Steel

Driving Spike

The driving spikes are made of re-usable high tensile strength steel which can be use multiple times. It is also suitable for power hammering.

Part No.	Thread Diameter (inch)	Material
EDSP58	5/8	High Tensile Steel
EDSP34	3/4	High Tensile Steel

Earth Plate



Solid copper plate is made from 99.9% pure copper which can be used for area where it is difficult to drive a rod or space is limited. It can also be used to improve earth resistance.

Earth Copper Plate - Solid Copper

Part No.	Size (L x W x H) (mm)	Total Surface Area (mm ²)	Weight (Kg)
CP603-C	600 x 600 x 3	0.73	9.74
CP903-C	900 x 900 x 3	1.63	21.74

**Other dimensions and copper purity are available upon request
Oxygen-free copper plates are also available

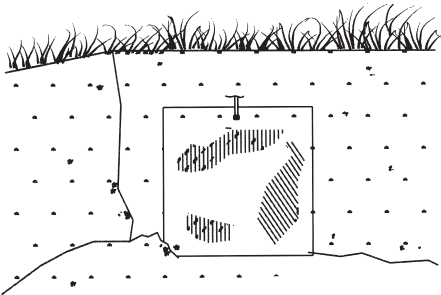

Earth Plate

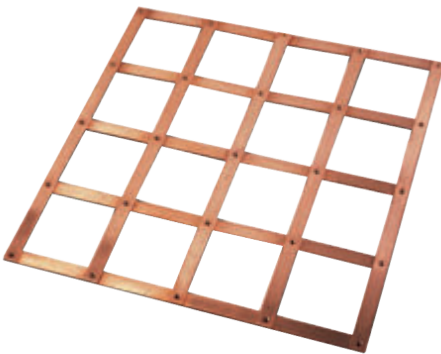

Lattice copper plate is made from 99.9% pure copper strips which can be used for area where it is difficult to drive a rod. It can also be used to improve earth resistance. This is a cost-effective solution as compared to solid copper plate but require a certain installation area to achieve similar results.

Earth Copper Plate - Lattice Copper

Part No.	Size (L x W x H) (mm)	Total Surface Area (mm ²)	Weight (Kg)
CL603-C	600 x 600 x 3	0.31	3.98
CL903-C	900 x 900 x 3	0.65	7.20

**Other dimensions and grid size are available upon request*

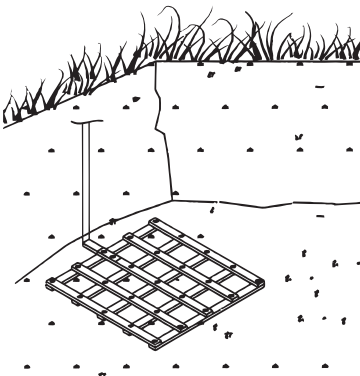

Heavy Duty Earth Inspection Pit

Made from high performance polymer, the earth pit provides excellent resistant against chemicals and UV radiation. Load rating is 5 tons which can be used in most conditions.



Heavy Duty Earth Inspection Pit

Part No.	Dimension (L x W x H) (mm)
HDEP50-P	300 x 300 x 220

Lightweight Earth Inspection Pit

Our lightweight inspection pit offers a economical and durable solution for earth pit chamber. The hot dipped galvanised lid offer good corrosion protection.

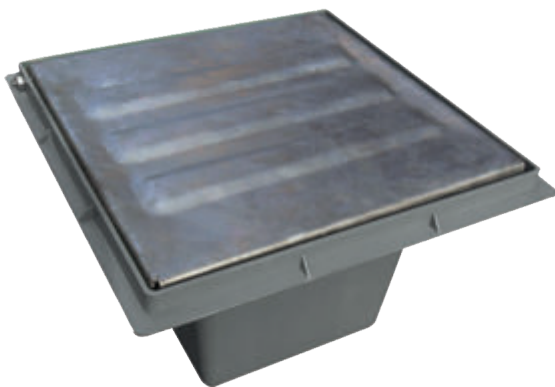

Lightweight Earth Inspection Pit

Part No.	Dimension (L x W x H) (mm)
LWEP	266 x 266 x 196

Concrete Earth Inspection Pit

Our concrete earth inspection pit is load rated to 4.5 tons and is suitable for most application.



Concrete Earth Inspection Pit

Part No.	Dimension (L x W x H) (mm)
CNEP-1	280 x 280 x 190
CNEP-2	345 x 345 x 210
CNEP-2-G	345 X 345 X 210 (with groove to fit earth bar)
CNEP-3	300 x 300 x 400 (With mild steel cover)

Earth Bar For Use In Earth Pit

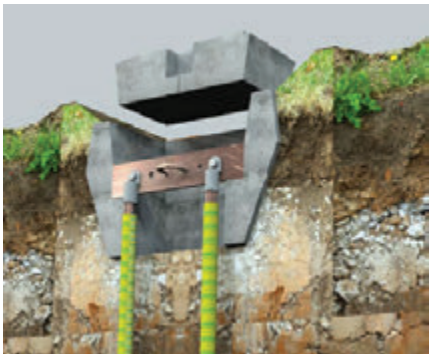

Our hard drawn high conductivity copper bar meets the IEC standards. Tinned copper bar is available upon request. The Earth Bar are pre-drilled with the required holes.

Earth Bar for use in Earth Pit

Part No.	No. of hole x Hole Size (mm)	Earth Bar Dimension (mm)	Earth Pit Model
CB506-230L-5H-10D	5 x 10.5mm Dia	50 x 6 x 230	CNEP-2

**Tinned Earth Bar are available upon request*

Earth clamps are made from high quality copper which is corrosion resistance, high mechanical strength and high conductivity. Its long lifespan ensures that the earthing system continuous performance.

Earth Clamp



IEC 62561-1:2017

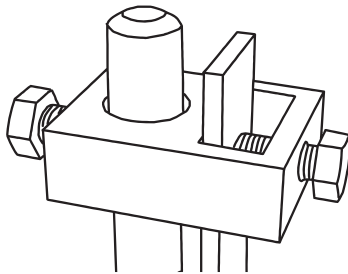

Rod to Tape Clamp

Part No.	Max Rod Diameter (inch)	Tape Conductor Range (mm)
CBEC58-C	5/8	25 x 3 - 25 x 6

Earth Clamp

Earth Rod Clamp



Part No.	Max Rod Diameter (inch)	Tape Conductor Range (mm)
CBEC16-2x253-C	3/4	25 x 3 - 25 x 6

Earth Clamp



IEC 62561-1:2017



Rod to Two Cable Clamp

Part No.	Max Rod Diameter (mm)	Cable Conductor Range (mm ²)
CBB1625-C	15	16 - 25
CBB5095-C	15	50 - 95
CBB120240-C	15	120 - 240

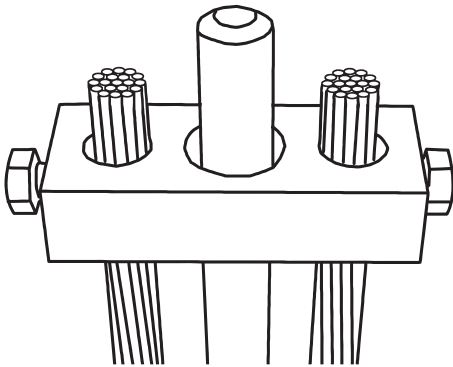

Earth Clamp



IEC 62561-1:2017



Rod to Tape Clamp (Type A)

Part No.	Max Rod Diameter (mm)	Max Tape Width (mm)
CRT1625-C	16	25
CRT2050-C	20	50

**Other sizes are available upon request*

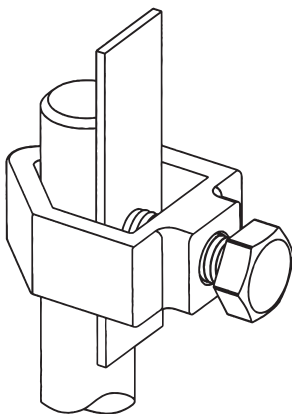

Earth Clamp



IEC 62561-1:2017

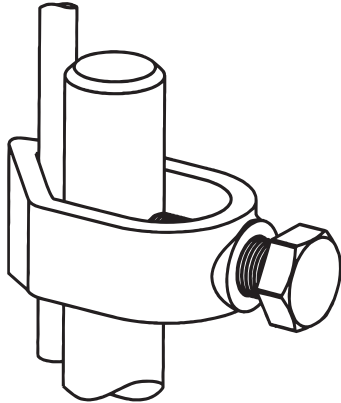
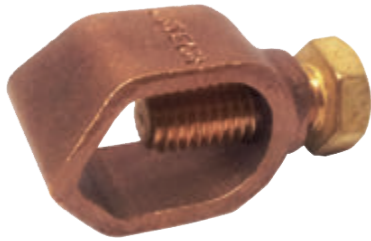

Rod to Cable Clamp (Type G)

Part No.	Max Rod Diameter (mm)	Cable Conductor Range (mm ²)
CRC1470-C	14	16 - 70
CRC1695-C	16	16 - 95
CRC20120-C	20	35 - 120

**For larger rod size or cable size, we recommend our GUV type of earth rod clamp*

Our heavy duty and versatile rod to cable clamps are made from high quality copper for lasting quality and corrosion resistance. It allows connection between earth rod to cables /rebar to cables. We offer a comprehensive solution for connection to a single cable, two cables, three cables or cables with copper tapes. Custom made solutions available upon request.

Earth Clamp - U Bolt Type



IEC 62561-1:2017

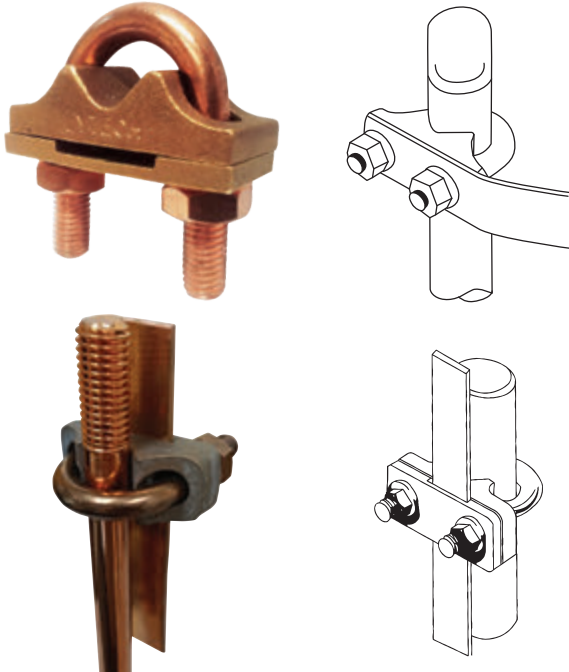

U-Bolt Rod to Tape Clamp (Type E)

Part No.	Max Rod Diameter (mm)	Max Tape Dimension (mm)
CRTE20-C	20	26 x 12
CRTE20-CT	20	26 x 12

**CRTE20-CT allows tape to be clamped without drilling*

Earth Clamp - U Bolt Type



IEC 62561-1:2017

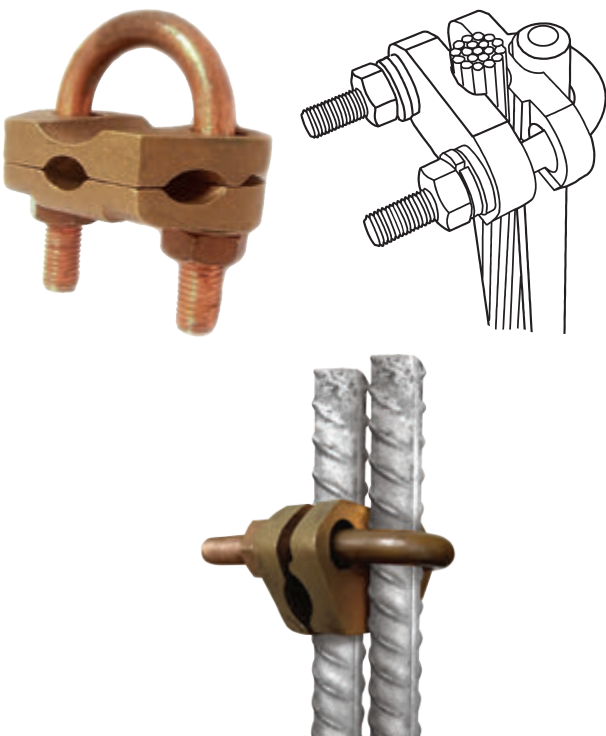

U-Bolt Rod to Cable Clamp (Type GUV)

Part No.	Max Rod Diameter (mm)	Cable Conductor Range (mm ²)
CUB1695-C	15	16 - 95
CUB20185-C	20	70 - 185
CUB20300-C	20	150 - 300
CUB25185-C	25	70 - 185

Earth Clamp - U Bolt Type

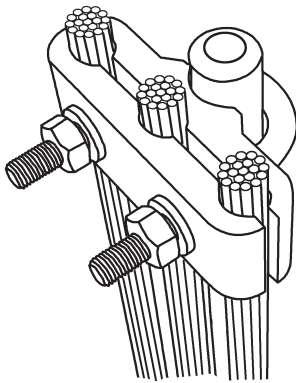

U-Bolt Rod to Three Cable Clamp (Type GUV)

Part No.	Max Rod Diameter (mm)	Cable Conductor Range (mm ²)
C3UB5070-C	20	50 - 70
C3UB70120-C	20	70 - 120

Earth Boss

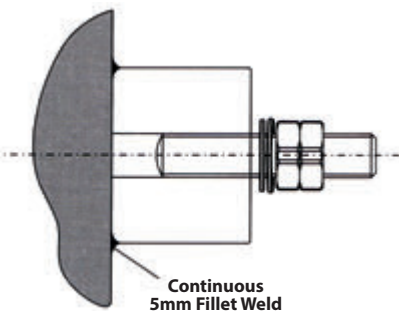

Manufactured from high tensile mild steel to BS 970 230M07 (ENIA) c/w SS316 stud, nuts and washers. It is used commonly for welding to steel vessels, tanks and structures for earthing application.

Earth Boss - Mild Steel

Part No.	Length (mm)	Diameter (mm)	Thread Diameter
EB3040-MS	30	40	M10
EB5050-MS	50	50	M10
EB3050-MS	30	50	M10
EB4040-MS	40	40	M10

**Other sizes are available upon request*

**Material for bolts, nuts and washers can be changed upon request*

Earth Boss

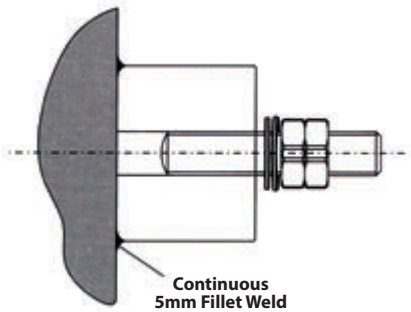

Manufactured from high quality SS316 material, it comes with SS316 stud, nuts and washers. It is commonly welded to steel vessels, tanks and structures for earthing application. Suitable for use in highly corrosive environment.

**SS304 & SS Duplex are available upon request*

Earth Boss - Stainless Steel 316

Part No.	Length (mm)	Diameter (mm)	Thread Diameter
EB3040-SS	30	40	M10
EB5050-SS	50	50	M10
EB3050-SS	30	50	M10
EB4040-SS	40	40	M10

**Other sizes are available upon request*

**Material for bolts, nuts and washers can be changed upon request*

Earth Point

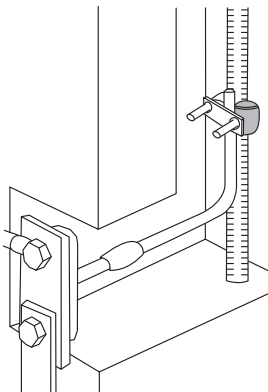
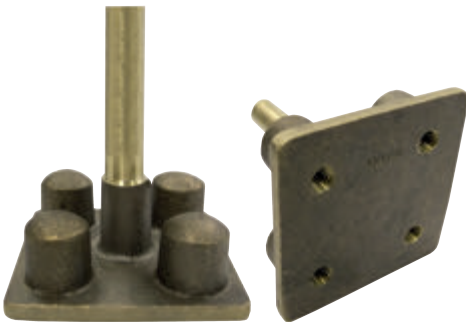

Manufactured from high quality copper material. Pre-welded cable tail using standard 70mm² PVC cable and exothermic welding process to form a permanent and highly conductive joint.

Part No.	Description	Hole Size (mm)
1HEP-C	One Hole Earth Point	M10 x 15
2HEP-C	Two Hole Earth Point	M8 x 12
4HEP-C	Four Hole Earth Point	M8 x 14
1HEP500-C	One Hole Earth Point with 500mm of Pre-welded 70mm ² PVC Cable	M10 x 15
2HEP500-C	Two Hole Earth Point with 500mm of Pre-welded 70mm ² PVC Cable	M8 x 12
4HEP500-C	Four Hole Earth Point with 500mm of Pre-welded 70mm ² PVC Cable	M8 x 14

**Different lengths of pre-welded cable are available upon request*

Static Earth Receptacle



This is used mainly in runways or road ways to provide a static discharge point for aircraft, fuel tankers etc.

Facilities like airports and petrol kiosk will require this product. Our receptacle is casted using high quality copper material strength.

Part No.	Conductor Type
----------	----------------

STRE85-C

Copper

**Different lengths of pre-welded cable or copper tapes are available upon request*

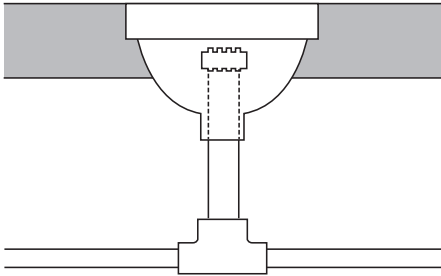

LYTECH CCER Series, static grounding reel provides convenient storage of grounding cable with fast payout and automatic spring rewind. Designed for safe and reliable grounding of vehicles, aircraft and other equipment requiring static bonding. This series come supplied with 20m of coated galvanised steel cable and are finished in our highly visible and durable yellow powder coated finish.

Static Grounding Reel

Model	Cable Length	O.D	Max Resistance	Reel Dimensions (mm) W x D x H	Weight (Kg)
CCER-320-1	20m	3mm	2.0 ohm	107 x 240 x 273	7



FEATURES

- Heavy-Duty steel construction
- Fully automatic spring rewind
- Supplied with coated galvanised cable
- 50 amp grounding clamp supplied as standard
- Latching of cable at any length
- Factory lubricated main spring assembly
- 20m capacity
- Ideal for use with refuelling reels
- **2 years manufacturers warranty**

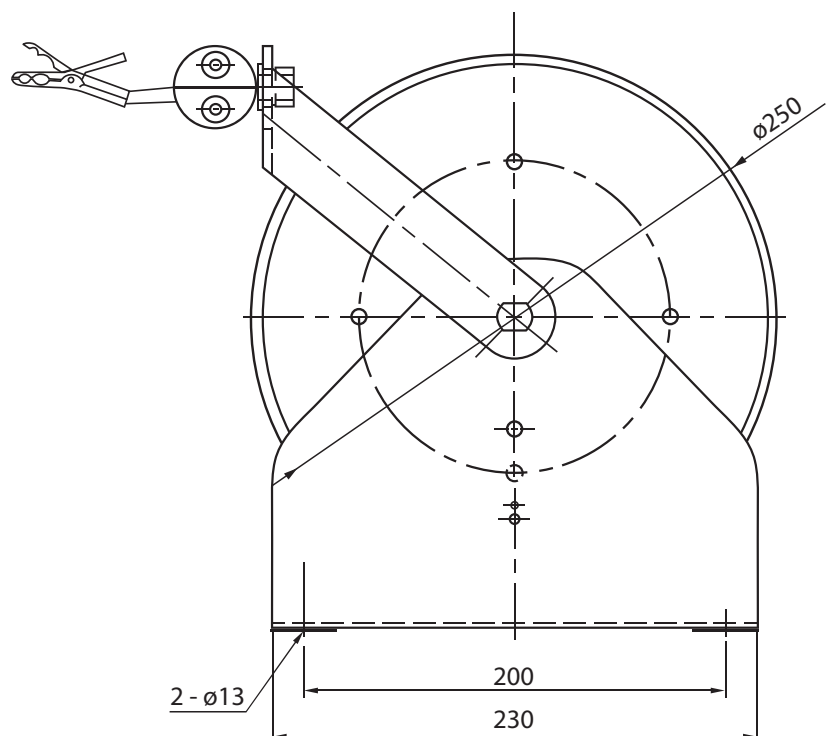
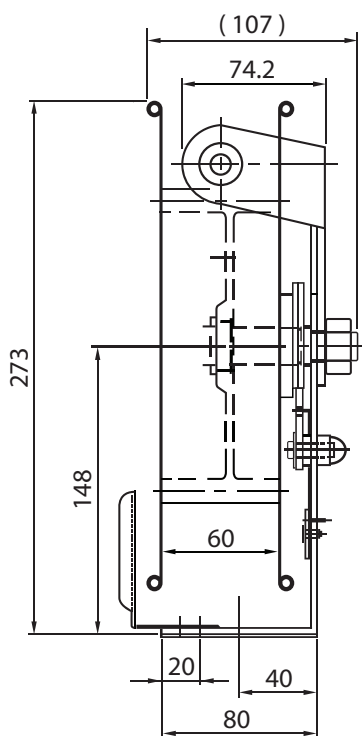

LYTECH Heavy Duty Static Ground Clamp (Stainless Steel) c/w cable for easy operation and designed for safe and reliable grounding for vehicles, aircraft and other equipment that required static bonding.

Static Grounding Clamp With Cable



Part No.

SGC2300-SS

Clamp
Material

Stainless Steel

Rebar Earth Set

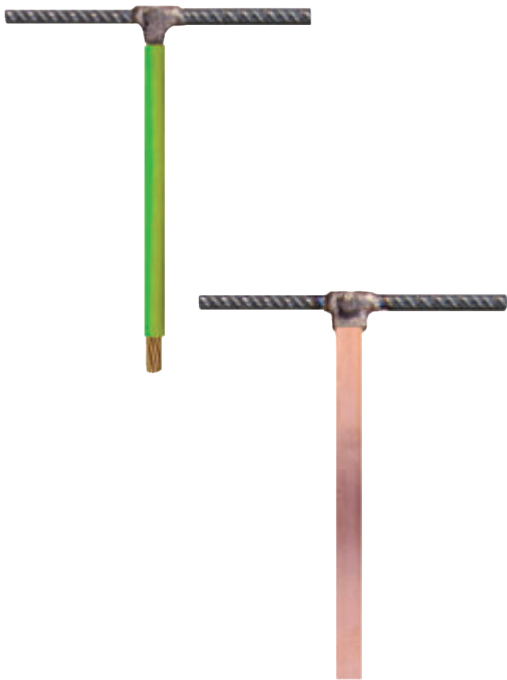

Provide a wide range of pre-welded rebar earth set that enable an easy connection to the rebar on site. This is used when structure rebar or a dedicated rebar is being used as the down conductor. With our pre-welded set, all you need is to arc-weld the rebar set on site. The joint uses exothermic welding process to form a permanent & highly conductive joint.

Part No.	Description
CTRES-500	T10 Rebar Pre-welded to 500mm of 25mm x 3mm Copper Tape
CCRES-500	T10 Rebar Pre-welded to 500mm of 70mm ² Copper Cable

**Standard length of rebar is 200mm*

**Different lengths of rebar and pre-welded conductors are available upon request*

Pipe Clamp for Earthing

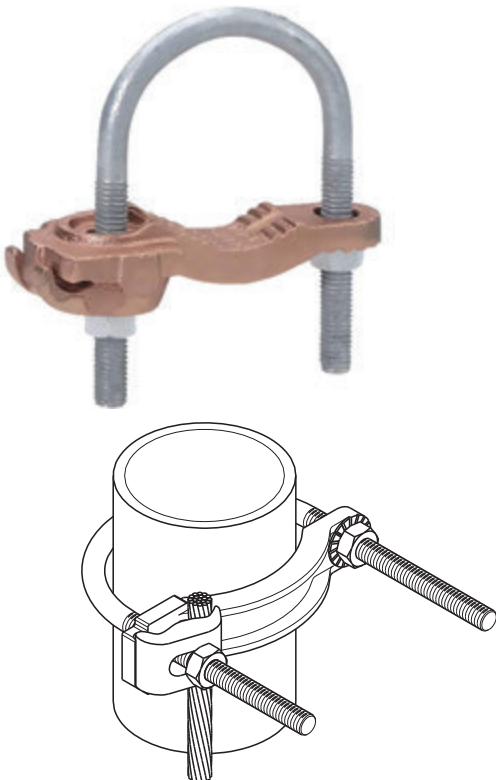

Part No.	Pipe Description (")	(mm)	Conductor Range (mmsq)
LPCB195	1/2 to 1	13 to 25	25 to 95
LPCB295	1-1/4 to 2	32 to 50	25 to 95
LPCB395	2-1/2 to 3-1/2	65 to 90	25 to 95
LPCB2-120	1-1/4 to 2	32 to 50	120
LPCB3-120	2-1/2 to 3-1/2	65 to 90	120

Our earth bars are made from high conductivity copper bar that meet the IEC 62561-1 Class H standards. The earth bars are tinned for corrosion protection. Each hole / way is provided with one set of SS316 hex bolt, washer, nut and lock washer.

**For non-tinned earth bars or custom made dimensions, please indicate during ordering*

Earth Bar



Part No.	No. of Holes	Dimension (W x H x L) (mm)	Cable Lug Size
EB506-6W-C	6	50 x 6 x 330	M10
EB506-8W-C	8	50 x 6 x 410	M10
EB506-10W-C	10	50 x 6 x 490	M10
EB506-12W-C	12	50 x 6 x 570	M10
EB506-14W-C	14	50 x 6 x 690	M10
EB506-16W-C	16	50 x 6 x 770	M10
EB506-18W-C	18	50 x 6 x 850	M10
EB506-20W-C	20	50 x 6 x 930	M10

Earth Bar with Omega Base



Part No.	No. of Holes	Dimension (W x H x L) (mm)	Cable Lug Size
EB506-6W-C-B	6	50 x 6 x 330	M10
EB506-8W-C-B	8	50 x 6 x 410	M10
EB506-10W-C-B	10	50 x 6 x 490	M10
EB506-12W-C-B	12	50 x 6 x 570	M10
EB506-14W-C-B	14	50 x 6 x 690	M10
EB506-16W-C-B	16	50 x 6 x 770	M10
EB506-18W-C-B	18	50 x 6 x 850	M10
EB506-20W-C-B	20	50 x 6 x 930	M10

Earth Bar with HDG Base

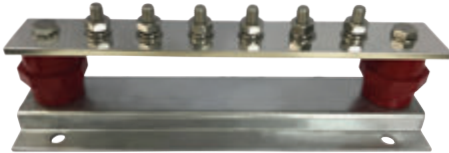

Part No.	No. of Holes	Dimension (W x H x L) (mm)	Cable Lug Size
EB506-6W-C-B(HDG)	6	50 x 6 x 330	M10
EB506-8W-C-B(HDG)	8	50 x 6 x 410	M10
EB506-10W-C-B(HDG)	10	50 x 6 x 490	M10
EB506-12W-C-B(HDG)	12	50 x 6 x 570	M10
EB506-14W-C-B(HDG)	14	50 x 6 x 690	M10
EB506-16W-C-B(HDG)	16	50 x 6 x 770	M10
EB506-18W-C-B(HDG)	18	50 x 6 x 850	M10
EB506-20W-C-B(HDG)	20	50 x 6 x 930	M10

**Non-Metallic Base (uPVC Base) is available upon request*

Earth Bar With Single Disconnecting Link With HDG Base

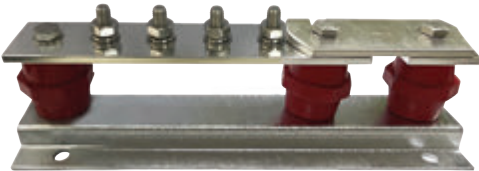

Part No.	No. of Holes	Dimension (W x H x L) (mm)	Cable Lug Size
EB506-6W-C-1L(HDG)	6	50 x 6 x 430	M10
EB506-8W-C-1L(HDG)	8	50 x 6 x 510	M10
EB506-10W-C-1L(HDG)	10	50 x 6 x 590	M10
EB506-12W-C-1L(HDG)	12	50 x 6 x 670	M10

**Non-Metallic Base (uPVC Base) is available upon request*

Earth Bar With Twin Disconnecting Link With HDG Base

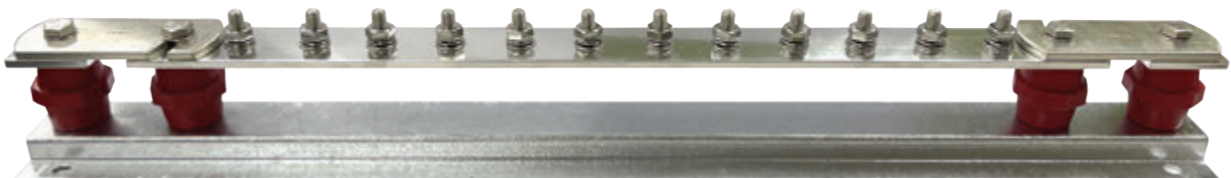

With 2 Disconnecting Link

Part No.	No. of Holes	Dimension (W x H x L) (mm)	Cable Lug Size
EB506-6W-C-2L(HDG)	6	50 x 6 x 530	M10

Continue next page ---

Earth Bar With Twin Disconnecting Link With HDG Base

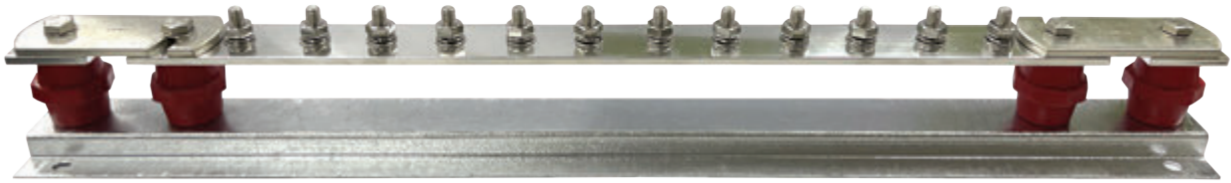

With 2 Disconnecting Link

Part No.	No. of Holes	Dimension (W x H x L) (mm)	Cable Lug Size
EB506-8W-C-2L(HDG)	8	50 x 6 x 610	M10
EB506-10W-C-2L(HDG)	10	50 x 6 x 690	M10
EB506-12W-C-2L(HDG)	12	50 x 6 x 770	M10

**Non-Metallic Base (uPVC Base) is available upon request*

Disconnecting Link With HDG Base



Part No.	Dimension (W x H x L) (mm)	Cable Lug Size
EB506-DL125-C(HDG)	50 x 6 x 125	M10

Insulator



Part No.	Height (H) (mm)	Insert (mm)	Diameter (AF) (mm)	Suitable For
INS-005L	50	M10	46	Insulator for Earth Bar

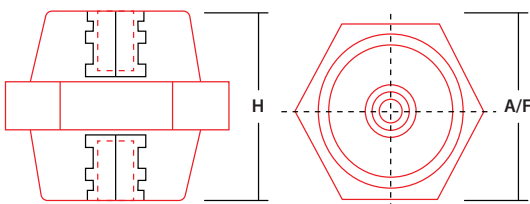

C Connector

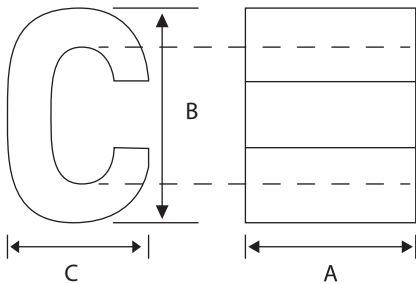
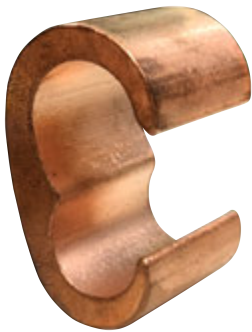

Part No.	Main Conductor Cable (mmsq)	Conductor Range (mmsq)
CCN-54720L	25	4 - 10
	16	10 - 16
CCN-54730L	25	25
	35	4 - 16
CCN-54745L	50	35 - 50
	70	4 - 25
CCN-54755L	50	35 - 50
	70	25 - 70
	95	10 - 35
CCN-54760L	70	25 - 70
	120	10 - 50
CCN-54765L	70	35 - 70
	120	16 - 70
	150	10 - 70
CCN-54770L	95	70 - 95
	120	35 - 120
	185	16 - 70
CCN-54775L	120	70 - 150
	185	50 - 185
	240	16 - 120
CCN-54780L	185	70 - 185
	240	35 - 240

**Tinned C Connector available upon request*

**Add suffix "T" (eg. CCN-6-6-T)*

Denso Tape



Part No.	Tape Width (mm)	Roll Length (MTR)
DST-50-10M	10	50

Conduit Clamps



Conduit clamps are easy to install and universal to use on conduit pipes. Standard finishing: Electro-galvanised.

Part No.	Pipe Dia (inch)	Finishing
CONC-3/4-EG	¾	Electro-Galvanised
CONC-1-EG	1	Electro-Galvanised
CONC-1-1/2-EG	1½	Electro-Galvanised
CONC-2-EG	2	Electro-Galvanised
CONC-2-1/2-EG	2½	Electro-Galvanised
CONC-2-3/4-EG	2¾	Electro-Galvanised

**HDG and stainless steel material are available upon request*

U-Bolt



U-Bolts comes in standard Hot-Dipped Galvanised finishing.

Part No.	Pipe Dia (inch)	Finishing
U-Bolt-3/4-HDG	¾	Hot-Dipped Galvanised
U-Bolt-1-HDG	1	Hot-Dipped Galvanised
U-Bolt-1-1/2-HDG	1½	Hot-Dipped Galvanised
U-Bolt-2-HDG	2	Hot-Dipped Galvanised
U-Bolt-2-1/2-HDG	2½	Hot-Dipped Galvanised
U-Bolt-2-3/4-HDG	2¾	Hot-Dipped Galvanised

**Electro-galvanised and stainless steel material are available upon request*

Accessories for Mounting



Countersunk Wood Screw

Part No.	Size (inch)	Material
CSWS10-11/2	1½	Brass
CSWS12-11/2	1½	Brass



Round Head Wood Screw

Part No.	Size (mm)	Material
RHWSM4-20(SS)	M4x20	SS316
RHWSM6-25(SS)	M6x25	SS316



Round Head Rivet

Part No.	Size (mm)	Material
RHRM5-12(BR)	M5x12	Brass
RHWSM5-20(BR)	M5x20	Brass



Plastic Wall Plug

Part No.	Size (No.)	Colour
PWP-10	No.10	Red
PWP-12	No.12	Brown

Bolts, Nuts, Washer and Threaded Rod

LYTECH Technologies has a wide range of bolts, nuts, washers and threaded rod in **Stainless steel, Hot-Dipped Galvanised, Zinc Plated and Brass.**

Hex Bolt



Part No.	Size (mm)	Material
HBM6-25(SS)	M6 x 25	SS316
HBM6-30(SS)	M6 x 30	SS316
HBM8-25(SS)	M8 x 25	SS316
HBM8-30(SS)	M8 x 30	SS316
HBM10-30(SS)	M10 x 30	SS316
HBM10-35(SS)	M10 x 35	SS316
HBM12-30(SS)	M12 x 30	SS316
HBM12-35(SS)	M12 x 35	SS316

Countersunk Set Screw



Part No.	Size (mm)	Material
CSM6-30(SS)	M6x30	SS316
CSM8-30(SS)	M8x30	SS316
CSM10-30(SS)	M10x30	SS316
CSM12-40(SS)	M12x40	SS316

Nut



Part No.	Size (mm)	Material
LNM6(SS)	M6	SS316
LNM8(SS)	M8	SS316
LNM10(SS)	M10	SS316
LNM12(SS)	M12	SS316

Flat Washer



Part No.	Size (mm)	Material
FWM6(SS)	M6	SS316
FWM8(SS)	M8	SS316
FWM10(SS)	M10	SS316
FWM12(SS)	M12	SS316

Lock Washer



Part No.	Size (mm)	Material
LWM6(SS)	M6	SS316
LWM8(SS)	M8	SS316
LWM10(SS)	M10	SS316
LWM12(SS)	M12	SS316

Threaded Rod



Part No.	Size (mm)	Material
TRM6(SS)	M6	SS316
TRM8(SS)	M8	SS316
TRM10(SS)	M10	SS316
TRM12(SS)	M12	SS316

Authorised Distributor:



The content of this catalogue has been carefully checked for accuracy at the time of print. However, LYTECH Technologies doesn't give any warranty of any kind, express or implied, in this respect and shall not be liable for any loss or damage that may result from any use or as a consequence of any inaccuracies in or any omissions from the information which it may contain.

Copyright © 2020 LYTECH Technologies Copyright in these pages is owned by LYTECH Technologies except where otherwise indicated. No part of this publication may be reproduced, copied or transmitted in any form or by any means, without our prior written permission. Images, trademarks, brands, designs and technology are also protected by other intellectual property rights and may not be reproduced or appropriated in any manner without written permission of their respective owners. LYTECH Technologies reserves the right to change and improve any product specifications or other mentions in the catalogue at its own discretion and at any time. These conditions of use are governed by the laws of Singapore and the courts of Singapore shall have exclusive jurisdiction in any dispute.

LYTECH Technologies Ltd

85 Great Portland Street, London W1W 7LT

Tel: +44 20 3745 0614 | **Email:** marketing@lytech.uk | **Website:** www.lytech.uk

LYTECH Technologies Pte Ltd

55 Ubi Avenue 1, #06-13 Ubi 55 Singapore 408935

Tel: +65 6741 9108 | **Fax:** +65 6749 3244 | **Email:** sales@lytech.uk | **Website:** www.lytech.uk