

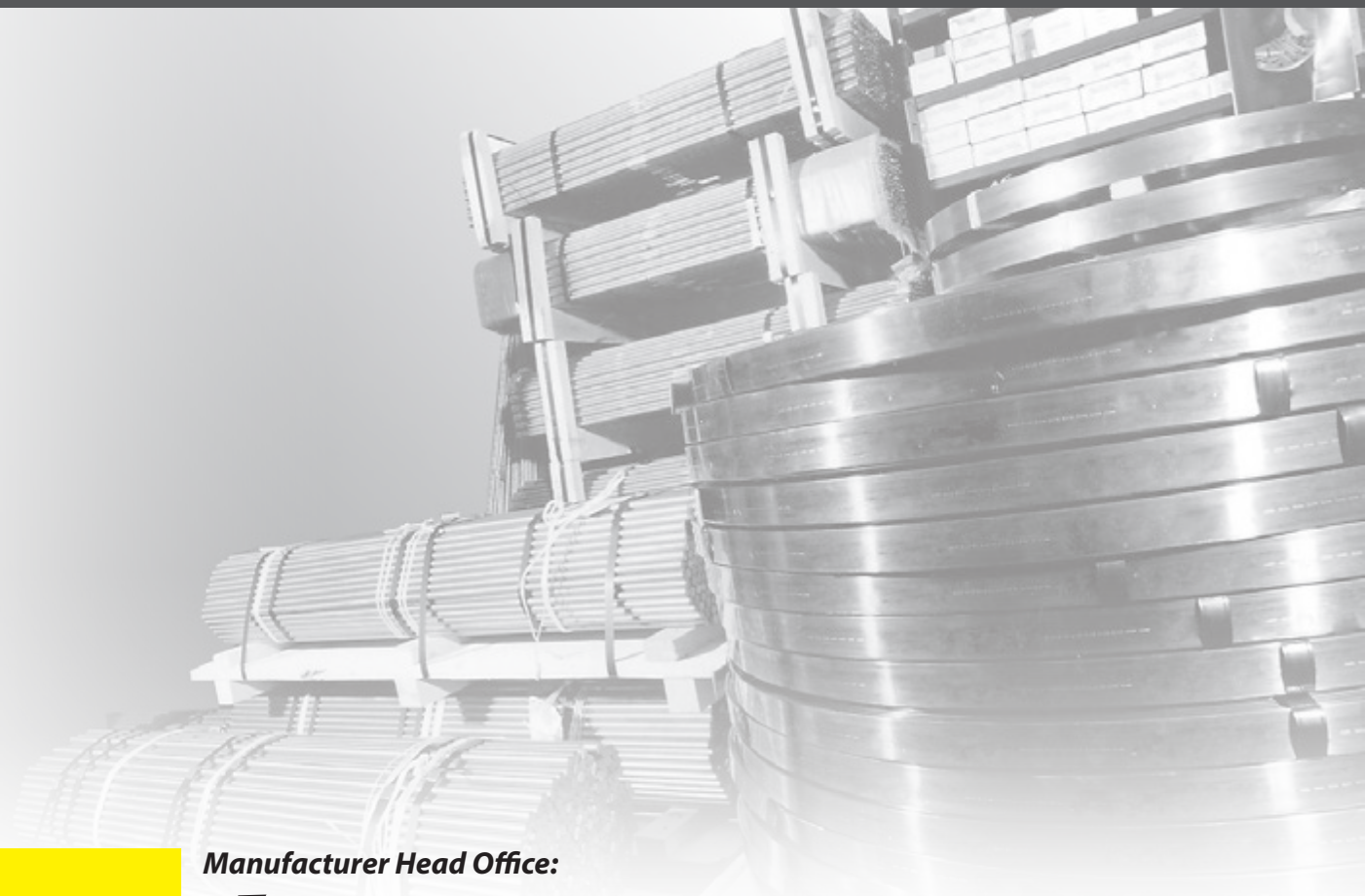

▶▶▶ *Direct Strike Lightning Protection*



Manufacturer Head Office:

 **LYTECH**

Email: sales@lytech.uk | marketing@lytech.uk
Website: www.lytech.uk

Ver : LYT-1-2

▶▶▶ About LYTECH Technologies

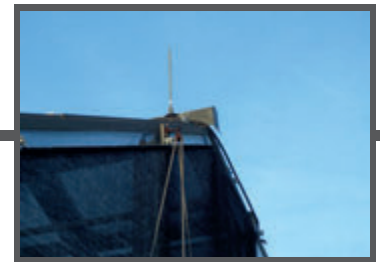

About

LYTECH Technologies provides a total solution from lightning protection and earthing systems to lightning and surge protection for electrical and electronic equipments.

Our lightning and earthing systems are manufactured strictly to the international standards such as **IEC 62561 and IEC 62305, UL Standards and Singapore Code of Practice SS555 for lightning protection.**

We control the quality of our products from raw materials to finished products to ensure top quality products are produced.

LYTECH Technologies provides a total solution for lightning protection from designing stage to supplying and installing a complete system. Our dedicated technical support team and sales team guarantee top quality service and select the most appropriate products to our customer's stringent demands.

LYTECH Technologies has participated in various mega projects in Singapore and around the South East Asia region.

▶▶▶ About LYTECH Technologies

LYTECH Technologies is a total solution provider for earthing, lightning and surge protection system in Asean.

Our Earthing and Lightning Protection System products (LYTECH) are manufactured to comply to **IEC 62561**, where the components have undergone **Salt Mist Test 60068-2-52:1996, severity 2 (72 hours exposure)**. Our dedication allows us to produce and customised products that cater to the demands of our customers.

Our lightning protection system design and lightning risk assessment reports complies to **IEC62305 / SS555 standards**. Our design team is also capable to propose design based on **American (UL, API) and French (NFC) standards**. With our capabilities and technical know how, we can offer sophisticated and customer orientated technical support, meeting our customers stringent requirements.

We based our earthing design on **IEEE80** and we use CDEGS software to produce efficient and safe earthing system via the simulation of fault current discharge on step and touch voltages.

With our expertise, quality service, adequate stocking and short decision making process, we are well placed to cater to your needs to earthing, lightning and surge protection system requirements.

■ Total Solution to Earthing and Lightning Protection System

LYTECH Technologies offers a total solution to all your earthing and lightning protection issues. With our technical know-how on the latest standards (**IEC, UL, API, NFC IEEE80**), besides offering the most optimum design, we can produce customised products to suit your project requirements.

Lightning is one of nature's most destructive phenomena, and can cause massive damage and destruction if a structure is not adequately designed and equipped with proper earthing, lightning and surge protection system. Sever cases even involved injuries and even death to personals.

The secondary effect of lightning, called surge or transient overvoltages, can easily damage electronics housed within the structure.

A reliable lightning protection system design, as per **IEC62305 / SS555**, encompasses both structural lighting (**part 3 - physical damage to structures and life hazard**) and surge protection system (**part 4 - electrical and electronic systems within structures**), complete with lightning risk assessment report (**part 2 - risk management**).

Apart from applying international standards to the lightning protection system, the lightning protection system components has to be correctly installed, using quality products and fixings to ensure the effective dissipation of lightning energy safely to the ground. Apart from the professional implementation, the lightning protection system has to be inspected at various intervals to ensure its effectiveness.

| LPS Level | Visual Inspection | Complete Inspection | Critical Facilities |
|-----------|-------------------|---------------------|---------------------|
| I & II | 1 year | 2 years | 1 year |
| III & IV | 2 years | 4 years | 1 year |

■ External Lightning Protection

The external lightning protection system is designed to protect a structure and the lives of people working within it, by directing the lightning energy in a safe manner to the earthing network. Using the Faraday Cage principle, the **LYTECH** range of quality lightning protection and earthing products ensures that safety and performance is not compromised.

Our products are tested under the following standards:

- **IEC 62561-1-2012**
Lightning protection system components (LPSC) – Part 1: Requirements for connection components
- **IEC 62561-2-2012**
Lightning protection system components (LPSC) – Part 2: Requirements for conductors and earth electrodes
- **IEC 62561-4-2010**
Lightning protection system components (LPSC) – Part 4: Requirements for conductor fasteners
- **Salt Mist Test 60068-2-52:1996, severity 2 (72 hours exposure)**

■ Earthing System

To ensure that our client always gets the most optimum design to meet the international standards, and their budget, we offer the following services :

- Lightning and surge protection system design and audit based on **IEC62305 / SS555, UL, API, and NFC standards**, complete with detailed drawings
- Soil resistivity and earth resistance test
- Training based on **IEC62305 / SS555**, and practical training on exothermic welding

■ Lightning Protection System Design

The earthing network ensures that lightning energy can be dissipated in a safe and efficient manner. Our range of LYTECH Exothermic Welding components provides a fast and easy way of creating good quality exothermic welding joints that can tolerate the fault current of all facilities.

■ Earthing System Design

Our design for earthing system is on **IEEE80** and we use the CDEGS software for Finite Element Analysis (FEA) of fault current discharge for step and touch voltages. To design an earthing system, our engineers can conduct a site survey and soil resistivity test and together with the fault current details, we can construct a total design complete with detail report which will also include step and touch voltages values clearly indicated within the earth mat.

▶▶▶ About LYTECH Technologies

■ LYTECH Technologies Advantage

We offer a one stop shop concept by providing total solution to earthing and lightning system design, and we keep stock for all common items.

Our design complies to all relevant international standards.

Our experience in this field allows us to provide our clients with optimum design that meet the international standard, as well as best use of resources

With our manufacturing expertise and experience, we can offer our clients customised solutions and products to meet their needs.





Certificate of Registration

QUALITY MANAGEMENT SYSTEM - ISO 9001:2015

This is to certify that:

Lytech Technologies Pte Ltd
51 Ubi Avenue 1
#05-22 Paya Ubi Industrial Building
Singapore 408933

Holds Certificate No:

FM 665172

and operates a Quality Management System which complies with the requirements of ISO 9001:2015 for the following scope:

The design, manufacture & sales of lightning and earthing materials

For and on behalf of BSI:

Michael Lam - Managing Director Assurance, APAC

Original Registration Date: 2017-01-14

Latest Revision Date: 2022-12-15

Effective Date: 2023-01-14

Expiry Date: 2026-01-13

Page: 1 of 1



...making excellence a habit.™

This certificate was issued electronically and remains the property of BSI and is bound by the conditions of contract.

An electronic certificate can be authenticated [online](#).

Printed copies can be validated at www.bsi-global.com/ClientDirectory or telephone + (65) 62700777.

Further clarifications regarding the scope of this certificate and the applicability of ISO 9001:2015 requirements may be obtained by consulting the organization. This certificate is valid only if provided original copies are in complete set.

Information and Contact: BSI, Kitemark Court, Davy Avenue, Knowlhill, Milton Keynes MK5 8PP. Tel: + 44 345 080 9000
BSI Assurance UK Limited, registered in England under number 7805321 at 389 Chiswick High Road, London W4 4AL, UK.
A Member of the BSI Group of Companies.

▶▶▶ **Direct Strike**



Air Terminal



IEC 62561-2:2018



Made from 99.98% solid copper or aluminium.
Various diameter and length of rods are available upon request.

| Part No. | Rod Diameter (mm) | Thread Diameter (inch) | Length (mm) | Material |
|----------|-------------------|------------------------|-------------|-----------|
| AT316-C | 14.2 | 5/8 | 300 | Copper |
| AT516-C | 14.2 | 5/8 | 500 | Copper |
| AT1016-C | 14.2 | 5/8 | 1000 | Copper |
| AT2016-C | 14.2 | 5/8 | 2000 | Copper |
| AT316-A | 14.2 | 5/8 | 300 | Aluminium |
| AT516-A | 14.2 | 5/8 | 500 | Aluminium |
| AT1016-A | 14.2 | 5/8 | 1000 | Aluminium |
| AT2016-A | 14.2 | 5/8 | 2000 | Aluminium |

**SS316 or 304 is available upon request.*



Multiple Point

Made from copper or aluminium.

| Part No. | Thread Diameter (inch) | Conductor Type |
|----------|------------------------|----------------|
| MP16-C | 5/8 | Copper |
| MP16-A | 5/8 | Aluminium |

Strike Pad

Use on parapet walls and open roofs where no conductors are visible.



| Part No. | Bolt Size | Material |
|----------|-----------|-----------|
| SP01-C | M10 | Copper |
| SP01-A | M10 | Aluminium |

**The standard threading is M10 and custom threading can be supplied upon request.*

Air Terminal Base for Flat Conductor



IEC 62561-1:2017

Made from copper or aluminium.



| Part No. | Conductor Size (mm) | Thread Diameter (inch) | Conductor Type |
|----------|---------------------|------------------------|----------------|
| TB16-C | 25 x 3 | 5/8 | Copper |
| TB16-A | 25 x 3 | 5/8 | Aluminium |

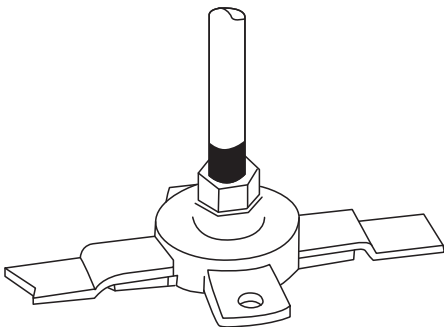

Air Terminal Base for Circular Conductor



It is used to connect copper cable conductor.

| Part No. | Conductor Size (mm) | Thread Diameter (inch) | Conductor Type |
|------------|---------------------|------------------------|----------------|
| TBC5835-C | 35 | 5/8 | Copper |
| TBC5850-C | 50 | 5/8 | Copper |
| TBC5895-C | 70 - 95 | 5/8 | Copper |
| TBC58120-C | 120 | 5/8 | Copper |

**Other cable sizes are available upon request.*

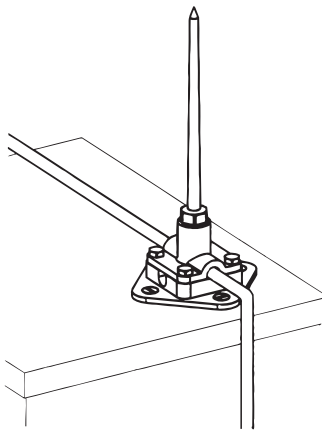

Ridge Saddle



Made from copper or aluminium.

It is commonly used for mounting air terminal rod to ridges roof.

| Part No. | Conductor Size (mm) | Thread Diameter (inch) | Conductor Type |
|----------|---------------------|------------------------|----------------|
| RG16-C | 30 x 6 | 5/8 | Copper |
| RG16-A | 30 x 6 | 5/8 | Aluminium |

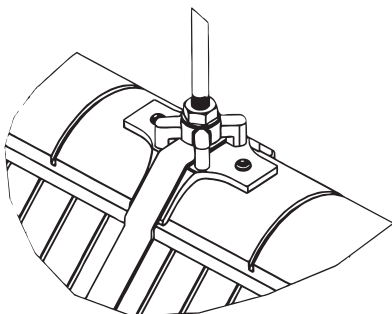

Adjustable Air Terminal Base for Flat Conductor

| Part No. | Conductor Size (mm) | Thread Diameter (inch) | Conductor Type |
|---------------|---------------------|------------------------|----------------|
| ATBC-16-253-C | 25 x 3 | 5/8 | Copper |

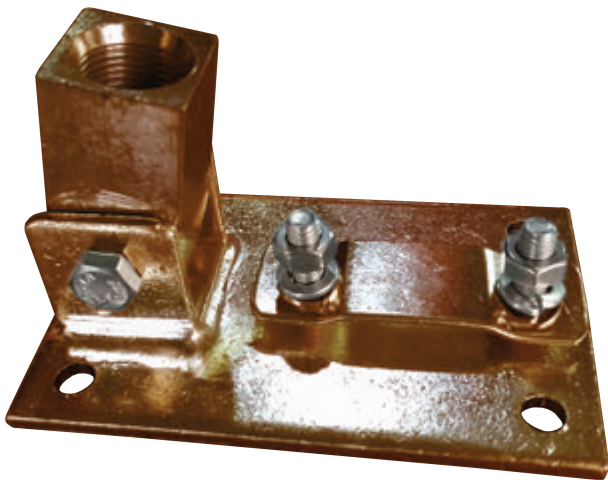

Adjustable Air Terminal Base for Circular Conductor

It is used to connect copper cable conductor.

| Part No. | Conductor Size (mm) | Thread Diameter (inch) | Conductor Type |
|--------------|---------------------|------------------------|----------------|
| ATBC 5835-C | 35 | 5/8 | Copper |
| ATBC 5850-C | 50 | 5/8 | Copper |
| ATBC 5895-C | 70-95 | 5/8 | Copper |
| ATBC 58120-C | 120 | 5/8 | Copper |

**Other cable sizes are available upon request.*

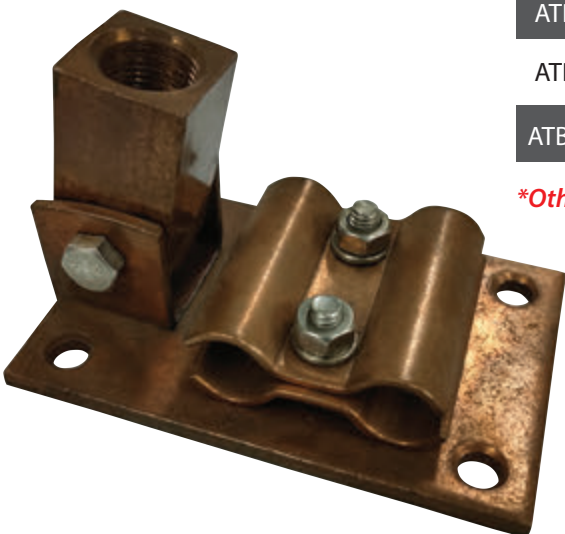

Square Clamp



IEC 62561-1:2017



For Tape System

Made from copper or aluminium.

| Part No. | Conductor Size (mm) | Conductor Type |
|----------|---------------------|----------------|
| SC253-C | 25 x 3 | Copper |
| SC506-C | 50 x 6 | Copper |
| SC253-A | 25 x 3 | Aluminium |
| SC506-A | 50 x 6 | Aluminium |

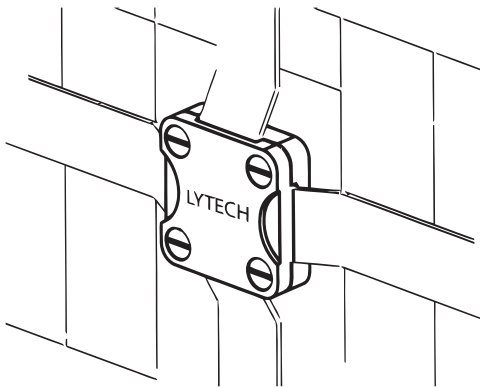

Square Clamp



Cable To Cable

For Circular Cable System.

| Part No. | Conductor Size (mm) | Conductor Type |
|----------|---------------------|----------------|
| SCC35-C | 35 | Copper |
| SCC50-C | 50 | Copper |
| SCC95-C | 70 - 95 | Copper |

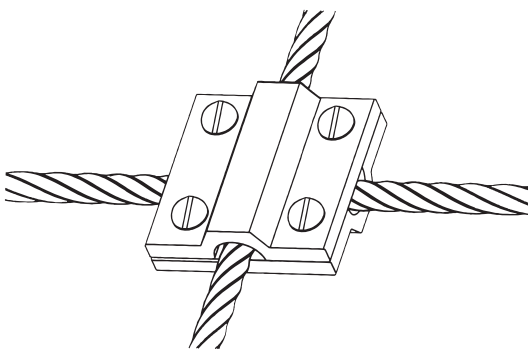

Square Clamp



Cable To Tape

| Part No. | Conductor Type | Size (mm) |
|----------------|----------------|-----------------------------|
| SCCT253 / 70-C | Copper | 25x3mm tape to 70mmsq cable |
| SCCT305 / 95-C | Copper | 30x5mm tape to 95mmsq cable |
| SCCT506 / 70-C | Copper | 50x6mm tape to 70mmsq cable |
| SCCT506 / 95-C | Copper | 50x6mm tape to 95mmsq cable |

B-Bond



IEC 62561-1:2017



Use for bonding tapes to steel structures.

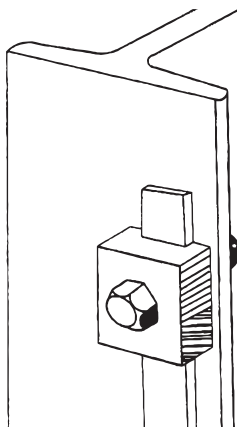

| Part No. | Bolt Size | Max Tape Width (mm) | Conductor Type |
|----------|-----------|---------------------|----------------|
| BB25-C | M10 | 26 | Copper |
| BB25-A | M10 | 26 | Aluminium |

Tower Earth Bond

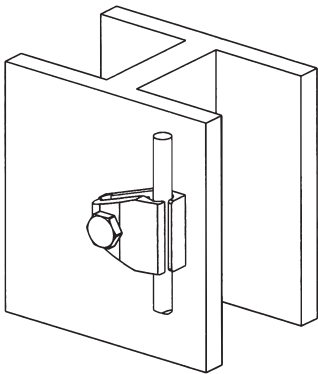

Made from copper.

The tower earth bond is suitable for tightening torque of 12Nm (as per IEC 62561-1). It is used for bonding copper cable to steel work. Clamps are available for flat tape system and circular cable system.

| Part No. | Conductor Size (mm ²) | Channel Thickness (mm) | Conductor Type |
|----------|-----------------------------------|------------------------|----------------|
| EB70-C | 16 - 70 | 10 | Copper |
| EB120-C | 70 - 120 | 10 | Copper |

RWP Bond

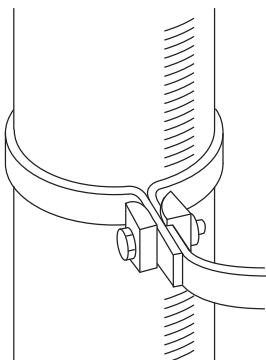

Use for bonding tape to rainwater pipe, handrail etc.

| Part No. | Bolt Size | Max Tape Width (mm) | Conductor Type |
|----------|-----------|---------------------|----------------|
| RWP25-C | M10 | 26 | Copper |
| RWP25-A | M10 | 26 | Aluminium |

Bonding

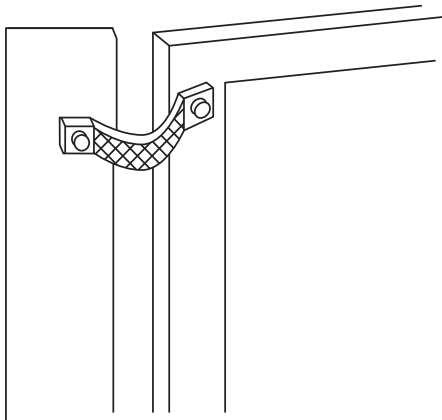

Our flexible copper braids are supplied as pre-cut with bonds at both ends for easy installation. This is usually used for earth bonding.

Tinned Flexible Copper Braid

| Part No. | Center to Center Dist. of Fixing Hole (mm) | Braid Dimension (mm) | Hole Size (mm) |
|-----------|--|----------------------|----------------|
| FCBT200-C | 200 | 25 x 3.5 | 12 |
| FCBT300-C | 300 | 25 x 3.5 | 12 |
| FCBT400-C | 400 | 25 x 3.5 | 12 |

Safety Earthing Strap with Safety Tag

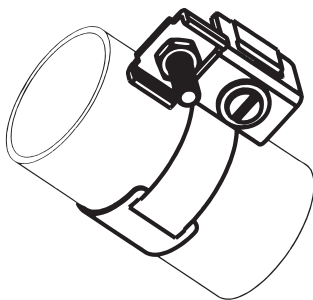

Made from stainless steel 304, it provides excellent corrosion protection and commonly used for earth bonding of small pipes. Customised length can be supplied for large pipe diameters.

| Part No. | Length (mm) | Material |
|-----------|-------------|----------|
| PES130-SS | 130 | SS304 |
| PES200-SS | 200 | SS304 |

**SS316 is available upon request.*

■ **Test Link Box**



The test link box is easy to install and is commonly used for test points where conductors are embedded within the structure.

| Part No. | Length (mm) | Material |
|----------|----------------|-----------|
| TLB-A | 125 x 125 x 38 | Aluminium |

**SS304 is available upon request.*

Made from copper or aluminium. High quality PVC saddle is also available for fastening PVC covered conductor. Other conductor dimensions are available upon request.

Conductor Saddle - Flat Conductor



IEC 62561-1:2017



Standard Tape Clip

| Part No. | Conductor Size (mm) | Conductor Type | Description |
|----------|---------------------|----------------|-------------|
| TC253-C | 25 x 3 | Copper | w/ Base |
| TC253-A | 25 x 3 | Aluminium | w / Base |

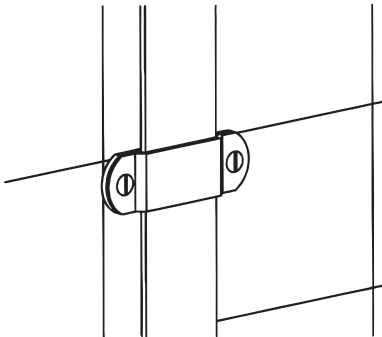

Conductor Saddle - Flat Conductor



IEC 62561-1:2017



DC Tape Clip

| Part No. | Conductor Size (mm) | Conductor Type |
|----------|---------------------|----------------|
| DCT253-C | 25 x 3 | Copper |
| DCT506-C | 50 x 6 | Copper |
| DCT253-A | 25 x 3 | Aluminium |
| DCT506-A | 50 x 6 | Aluminium |

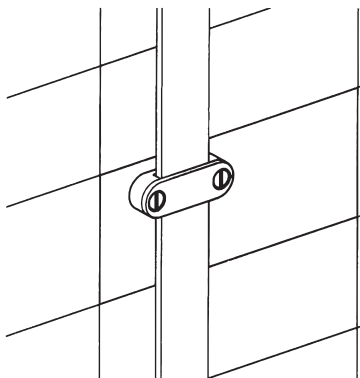

Conductor Saddle - Flat Conductor



PVC DC Tape Saddle for PVC Tape Conductor

| Part No. | Conductor Size (mm) | Colour | Material |
|------------|---------------------|--------|----------|
| DCP253-P-B | 25 x 3 | Brown | PVC |

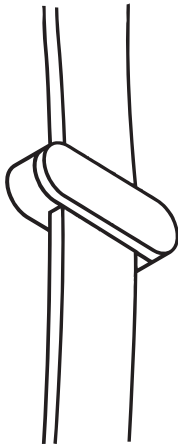

Conductor Saddle - Flat Conductor



Glue Down DC Tape Clip

| Part No. | Conductor Size (mm) | Colour | Material |
|------------|---------------------|--------|----------|
| GDT253-P-G | 25 x 3 | Grey | PVC |

**Other colors available upon request.*

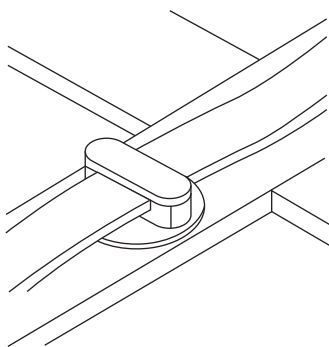

L-SP-250 Surface primer - 250 ml spray applicator (estimated application of approx 500 clips)



L-CS-500 Cleaning solution - 500 ml spray applicator For cleaning lacquered roofing membranes



Conductor Saddle - Flat Conductor

LYTECH Outdoor Self Adhesive Saddle with 3M™ VHB™ technology. It is being used together with our standard tape saddle. *Custom made configuration with other type of saddle or clamp is available upon request.*



Product Description

VHB+ is a conformable, very high bond acrylic foam tape which has added performance for bonding to plasticised vinyl due to a specially formulated adhesive which resists plasticiser migration. In addition this core adhesive composition makes the product well suited to many paints and primers.

Its improved conformability also allows more complete bond contact area when bonding rigid or irregular materials. The product has somewhat lower peel, tensile and shear performance than other VHB tape products due to its inherent softness. 4941's principal advantages are that it provides a more uniform seal on irregular surfaces, and invisible bonds under a transparent surface it offers a more aesthetically pleasing bond. 4941 is suitable for many interior and exterior industrial applications.



Standard Tape Clip with 3M™ VHB™

| Part No. | Conductor Size (mm) | Conductor Type |
|-------------|---------------------|----------------|
| TC253-C-VHB | 25 x 3 | Copper |
| TC506-C-VHB | 50 x 6 | Copper |
| TC253-A-VHB | 25 x 3 | Aluminium |



DC Conductor Saddle - Flat Conductor with 3M™ VHB™

| Part No. | Conductor Size (mm) | Conductor Type |
|--------------|---------------------|----------------|
| DCT253-C-VHB | 25 x 3 | Copper |
| DCT256-C-VHB | 25 x 3 | Copper |
| DCT506-C-VHB | 50 x 6 | Copper |
| DCT305-C-VHB | 30 x 5 | Copper |
| DCT253-A-VHB | 25 x 3 | Aluminium |



| Part No. | Pack Size |
|-----------------|-----------|
| LY3M-94-0.5PINT | 1/2 PINT |

**Larger pack size available upon request.*

Conductor Saddle - Circular Conductor

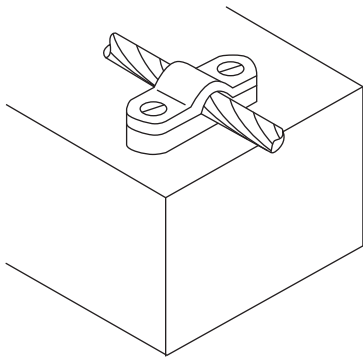

DC Circular Cable Saddle

| Part No. | Conductor Size (mm ²) | Conductor Type |
|----------|-----------------------------------|----------------|
| DCC50-C | 50 | Copper |
| DCC70-C | 70 | Copper |
| DCC95-C | 95 | Copper |

Conductor Saddle - Circular Conductor

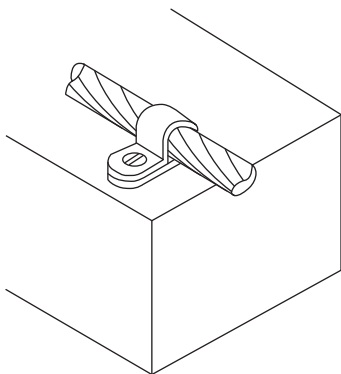

One Hole Cable Clip

| Part No. | Conductor Size (mm ²) | Conductor Type |
|----------|-----------------------------------|----------------|
| CC35-C | 25 - 35 | Copper |
| CC70-C | 50 - 70 | Copper |
| CC95-C | 95 | Copper |
| CC120-C | 120 | Copper |
| CC150-C | 150 | Copper |
| CC185-C | 185 | Copper |
| CC240-C | 240 | Copper |
| CC300-C | 300 | Copper |

Test Clamp



IEC 62561-1:2017



Oblong Test Clamp for Tape System

| Part No. | Max Conductor Size (mm) | Conductor Type |
|----------|-------------------------|----------------|
| OTC253-C | 26 x 8 | Copper |

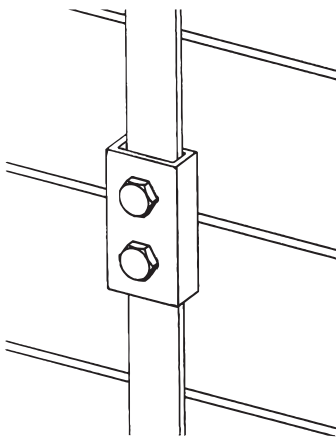

Test Clamp



IEC 62561-1:2017



Round Test Clamp for Tape System

| Part No. | Max Conductor Size (mm) | Conductor Type |
|-----------|-------------------------|----------------|
| RTC2612-C | 26 x 12 | Copper |

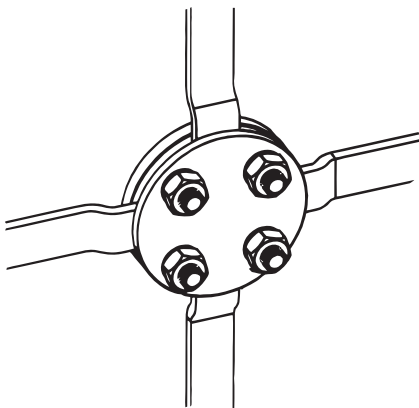

Test Clamp

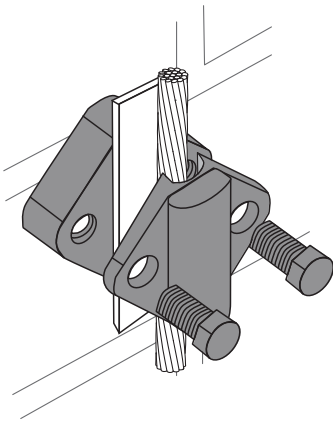

Cable To Tape

| Part No. | Conductor Type | Size (mm) |
|----------------|----------------|------------------------------|
| CTCT-253/120-C | Copper | 25x3mm tape to 120mmsq cable |
| CTCT-253/185-C | Copper | 25x3mm tape to 185mmsq cable |

Test Clamp

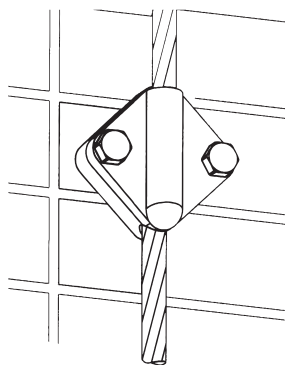

Circular Cable System

| Part No. | Conductor Size (mm ²) | Conductor Type |
|----------|-----------------------------------|----------------|
| CTC50-C | 50 | Copper |
| CTC70-C | 70 | Copper |
| CTC95-C | 95 | Copper |

■ **Test Clamp**



IEC 62561-1:2017

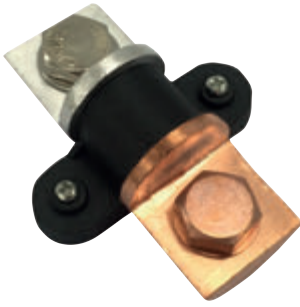

Bi-metallic Connector for Aluminium to Copper Tape System

| Part No. | Conductor Size (mm ²) | Conductor Type |
|-----------|-----------------------------------|--------------------|
| BMC253-AC | 25 x 3 | Aluminium / Copper |

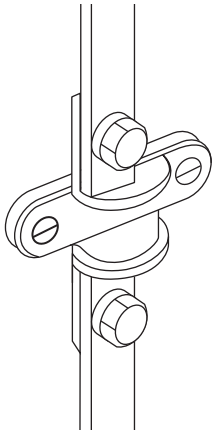

Special Clamp for Roof Application



Roof clamps are easy to install and universal to use on most type of metallic roof to mount conductor saddle or clamps without the need of drilling.

| Part No. | Max Ridge Thickness (mm) | Threading (mm) | Application |
|----------|--------------------------|----------------|--|
| RC-M6-A | 14 | M6 | To be use with other saddle and clamps |

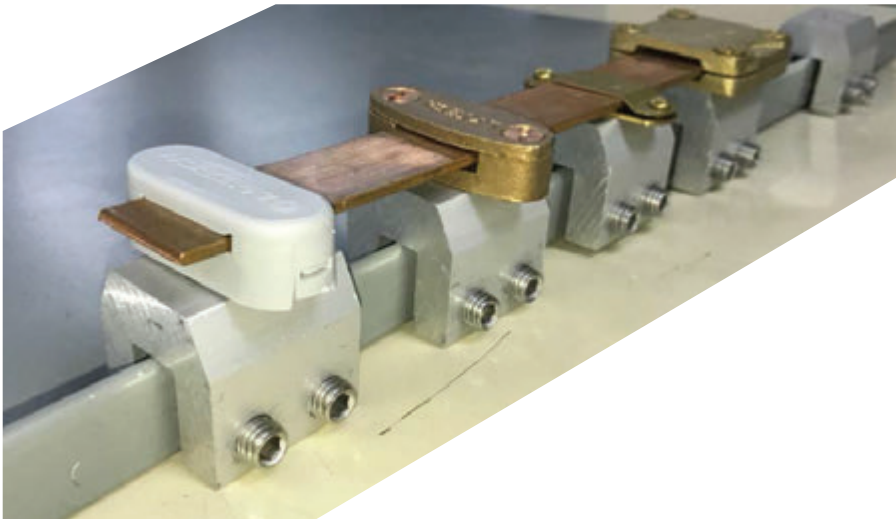
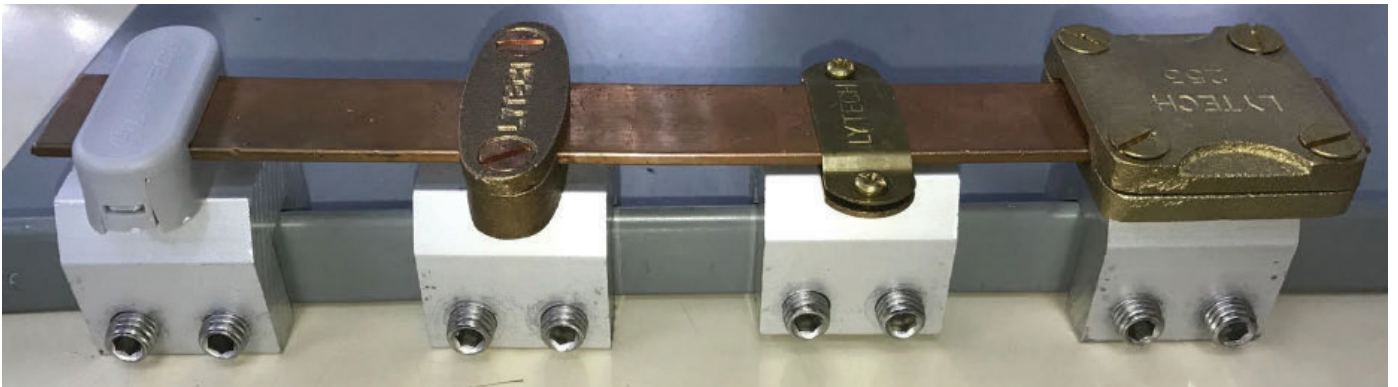



Flat Tape



IEC 62561-2:2018

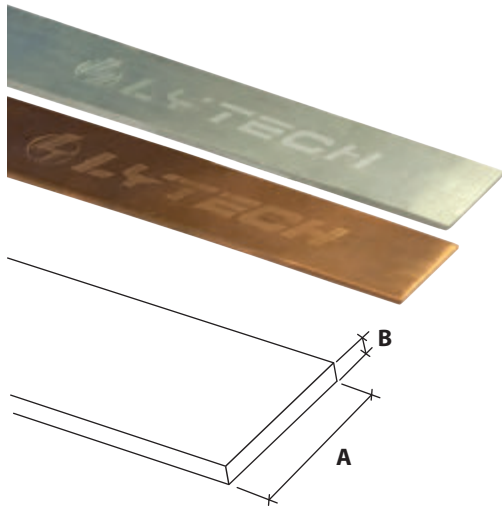

Please note that weight/meter is subjected to manufacturing tolerance.

Our flat tape conductor consists of 2 main choices of material, soft annealed copper tape of minimum 99.98% copper purity & aluminium tape.

Bare Copper Tape

| Part No. | Conductor Size (AxB) (mm) | Standard Coil Size (m) | Weight Per Metre (Kg) |
|----------|---------------------------|------------------------|-----------------------|
| FT253-C | 25 x 3 | 50 | 0.67 |
| FT506-C | 50 x 6 | 20 | 2.68 |
| FT5005-C | 50x0.5 | 150 | 0.22 |

**Other sizes are available upon request.*

Bare Aluminium Tape

| Part No. | Conductor Size (AxB) (mm) | Standard Coil Size (m) | Weight Per Metre (Kg) |
|----------|---------------------------|------------------------|-----------------------|
| FT253-A | 25 x 3 | 100 | 0.21 |

**Other sizes are available upon request.*

Flat Tape

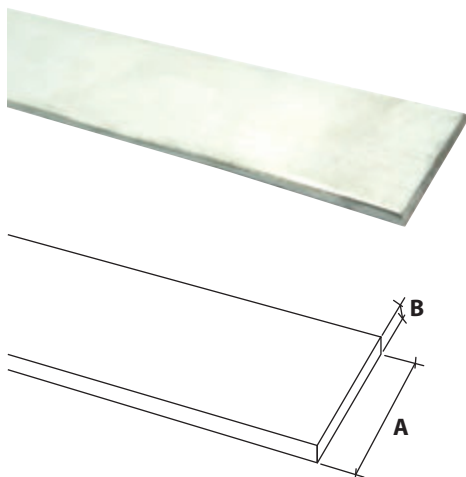

Our soft annealed copper tape is manufactured with minimum 99.98% copper purity and Tinned copper tape provides an additional protection against corrosion.

Tinned Copper Tape

| Part No. | Conductor Size (AxB) (mm) | Standard Coil Size (m) | Weight Per Metre (Kg) |
|----------|---------------------------|------------------------|-----------------------|
| FT253-CT | 25 x 3 | 50 | 0.67 |
| FT506-CT | 50 x 6 | 20 | 2.68 |

**Other sizes are available upon request.*

**Please note that weight / meter is subjected to manufacturing tolerance.*

Flat Tape

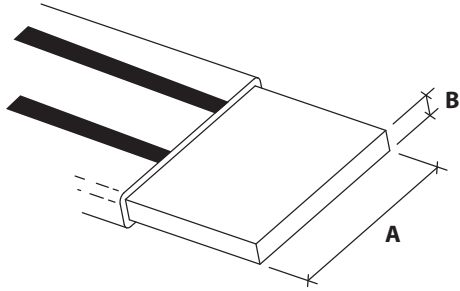
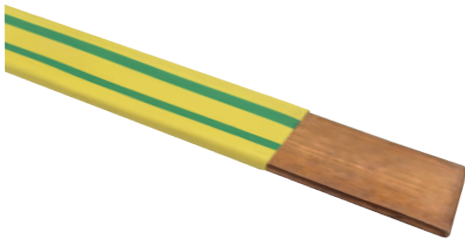

PVC (Green / Yellow) Copper Tape

| Part No. | Conductor Size (AxB) (mm) | Standard Coil Size (m) |
|----------------|---------------------------|------------------------|
| FTP253-C (G/Y) | 25 x 3 | 25 |

PVC (Green / Yellow) Aluminium Tape

| Part No. | Conductor Size (AxB) (mm) | Standard Coil Size (m) |
|----------------|---------------------------|------------------------|
| FTP253-A (G/Y) | 25 x 3 | 25 |

**Other sizes and colours are available upon request.*

Flat Bar



Our hard drawn high conductivity copper bar meets the IEC standards. Tinned copper bar is available upon request.

Hard Drawn Copper Bar

| Part No. | Conductor Size (mm ²) | Standard Length | Weight Per Metre (Kg) |
|----------|-----------------------------------|-----------------|-----------------------|
| CB253-C | 25x3 | 3 | 0.67 |
| CB506-C | 50x6 | 3 | 2.68 |

**Other sizes are available upon request.*

Authorised Distributor:



The content of this catalogue has been carefully checked for accuracy at the time of print. However, LYTECH Technologies doesn't give any warranty of any kind, express or implied, in this respect and shall not be liable for any loss or damage that may result from any use or as a consequence of any inaccuracies in or any omissions from the information which it may contain.

Copyright © 2020 LYTECH Technologies Copyright in these pages is owned by LYTECH Technologies except where otherwise indicated. No part of this publication may be reproduced, copied or transmitted in any form or by any means, without our prior written permission. Images, trademarks, brands, designs and technology are also protected by other intellectual property rights and may not be reproduced or appropriated in any manner without written permission of their respective owners. LYTECH Technologies reserves the right to change and improve any product specifications or other mentions in the catalogue at its own discretion and at any time. These conditions of use are governed by the laws of Singapore and the courts of Singapore shall have exclusive jurisdiction in any dispute.

LYTECH Technologies Ltd

85 Great Portland Street, London W1W 7LT

Tel: +44 20 3745 0614 | **Fax:** +44 20 7183 3073 | **Email:** marketing@lytech.uk | **Website:** www.lytech.uk

LYTECH Technologies Pte Ltd

51 Ubi Avenue 1, #05-22 Paya Ubi Industrial Park, Singapore 408933

Tel: +65 6741 9108 | **Fax:** +65 6749 3244 | **Email:** sales@lytech.uk | **Website:** www.lytech.uk